

Part Number: PTR11-47010

Kit Contents:

Item #	Quantity Req'd.	Description
1	1	PLUS Rear Sway Bar
2	1	Hardware Kit
3		

Hardware Box Contents

Item #	Quantity Req'd.	Description
1	1	Left - Sway Bar End Link with (2) M10 nuts
2	1	Right - Sway Bar End Link with (2) M10 nuts
3	2	Bushing
4	2	Bushing Bracket 2 pcs
5	1	Hardware Bag (4 - M8-1.25x 25 bolts, 4 - M8-1.25 lock nuts, 8 - washers)
6	1	Instruction Sheet
7	1	2cc Teflon® Synthetic Grease

Additional Items Required For Installation

Item #	Quantity Req'd.	Description
1		
2		
3		

Conflicts

None

Recommended Tools

Personal & Vehicle Protection	Notes
Vehicle Protection	Seat/Floor Covers
Safety Glasses	
Special Tools	Notes
2 short bungee cords	
Installation Tools	Notes
½" Impact Gun	For parts removal only
Torque Wrench	5 - 100 lbf-ft (0 - 135 N·m)
Socket/Ratchet	13, 17mm Socket
	14mm Crow Foot
Wrenches	13mm
Special Chemicals	Notes
Cleaner (for clean up)	3M Prepsolvent 70

General Applicability

All PRIUS Sedans

Recommended Sequence of Application







Item #	Accessory
1	Install RSB at the same time as lowering springs
2	

* Mandatory

Vehicle Service Parts (may be required for reassembly)

Item #	Quantity Req'd.	Description
1		
2		
3		

Legend

	STOP: Damage to the vehicle may occur. Do not proceed until process has been complied with.
	OPERATOR SAFETY: Use caution to avoid risk of injury.
	CAUTION: A process that must be carefully observed in order to reduce the risk of damage to the accessory/vehicle and to ensure a quality installation.
	TOOLS & EQUIPMENT: Used in Figures calls out the specific tools and equipment recommended for this process.
	REVISION MARK: This mark highlights a change in installation with respect to previous issue.
	SAFETY TORQUE: This mark indicates that torque is related to safety.

Care must be taken when installing this accessory to ensure damage does not occur to the vehicle. The installation of this accessory should follow approved guidelines to ensure a quality installation

These guidelines can be found in the "Accessory Installation Practices" document.

This document covers such items as:

- Vehicle Protection (use of covers and blankets, cleaning chemicals, etc.).
- Safety (eye protection, rechecking torque procedure, etc.).
- Vehicle Disassembly/Reassembly (panel removal, part storage, etc.).
- Electrical Component Disassembly/Reassembly (battery disconnection, connector removal, etc.).

1. Pre-installation Preparation

- Use Seat & Floor Protectors to avoid damage to surfaces.
- Lift vehicle using a drive on lift if available. If using a two post lift or jack use the lift points recommended in the owner's manual.

2. Hang Sway Bar Under Beam Axle

- Attach bungee cord to rear chassis reinforcement and rear coil spring, holding front of rear sway bar overhead (Fig. 2-1).

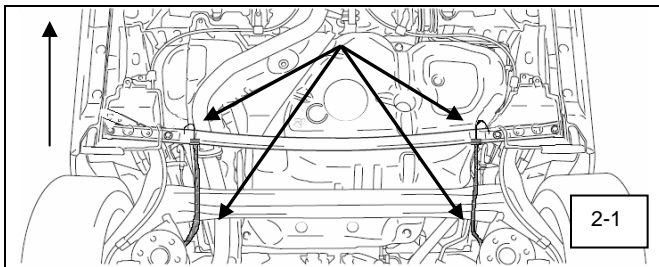

3. Install PLUS Rear Sway Bar (RSB)

- Remove lower shock mount bolt.
 - Remove bolt by turning the bolt not the lock nut.
 - If tires are not supported, place a high position jack stand under shock mount and relieve tension from shock absorber. (Fig. 3-1)

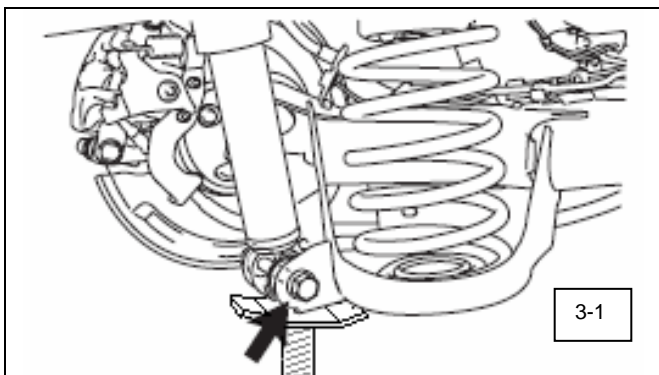

NOTE: If using a two post lift, only remove one shock bolt at a time so that the rear beam axle is not allowed to swing away from the vehicle causing stress to beam axle bushings.

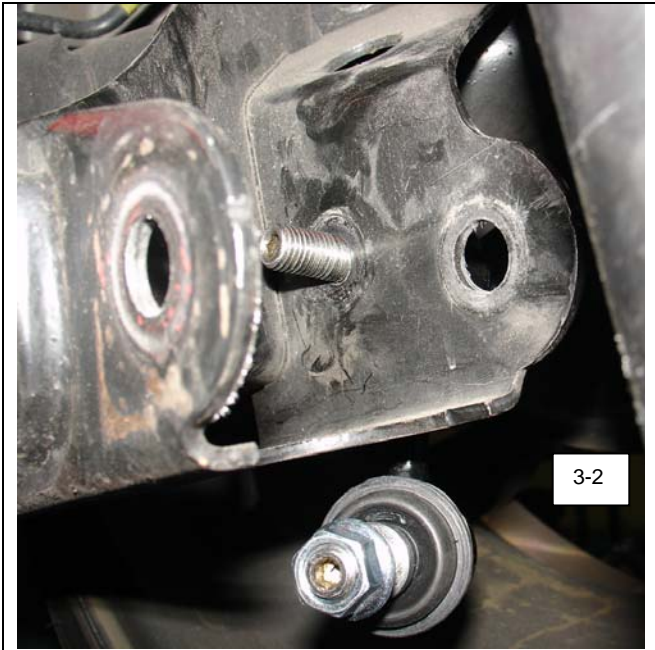

(b) Install end link onto lower shock mount.

(1) Insert link stud into hole just forward of outside shock bolt hole. (Fig 3-2)

NOTE: Links are handed, left and right. Lower stud should face towards the rear of the car. **Remove protective plastic boot covers before installation.**

(2) Install nut and tighten.

Torque: 44 N·m (49 kgf·cm, 32 ft·lbf)

NOTE: If the ball joint turns together with the nut, use a 5 mm hexagon wrench to hold the stud.

(c) Install lower shock assembly and hand tighten nut and bolt.

(d) Repeat steps a-c for other side.

(e) Insert lower link studs into the sway bar mounting tabs and tighten nuts. (Fig 3-3)

Torque: 44 N·m (49 kgf·cm, 32 ft·lbf)

NOTE: If the ball joint turns together with the nut, use a 5 mm hexagon wrench to hold the stud.



(f) Place bushing clamps onto rear beam axle.

(1) Measure inward from the beam axle reinforcement 9 ¼ inches or 23.5 cm. (Fig. 3-4)

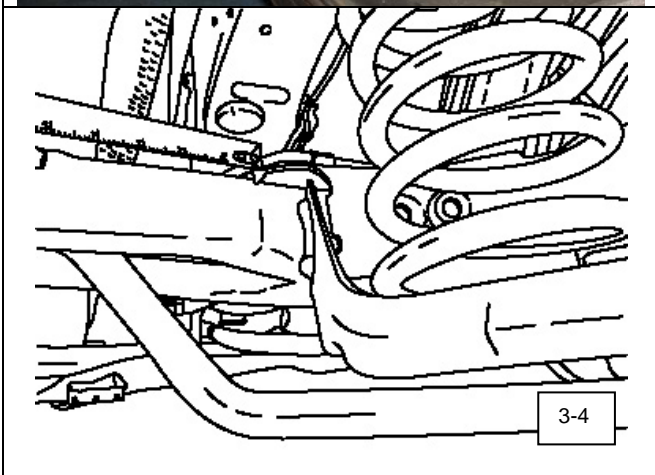

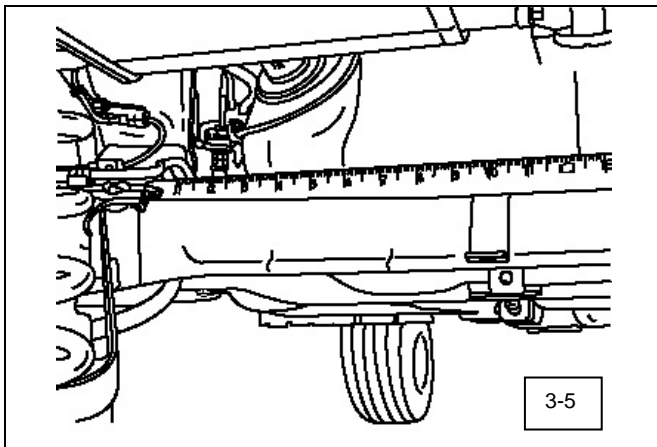

- (2) Place outside edge of clamps at this point on the beam axle. (Fig. 3-5)



- (g) Install sway bar bushings onto the bar.
 - (1) Apply supplied grease to round bore of the bushings
 - (2) Bushing should be installed between the welded locating rings. (Fig 3-6)
- (h) Swing sway bar up to the beam axle and locate the bar so that the bushings align with the bushing clamps. Then press bar and bushings up into the beam axle.

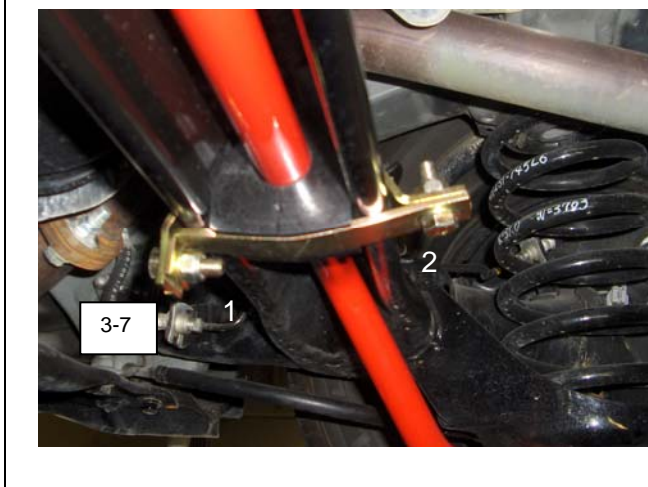

- (i) Fasten lower portion of clamp to the upper portion of clamp as shown. (Fig. 3-7)
 - (1) Orient bolts as shown.
 - (2) Tighten the horizontal bolt first then the vertical bolt second.

NOTE: Bracket must be oriented as shown in figure 3-5.

Torque: 31 N•m (300 kgf•cm, 24 ft•lbf)

HINT: Using the inner lips of the rear wheels as reference the sway bar should sit centered under the vehicle.

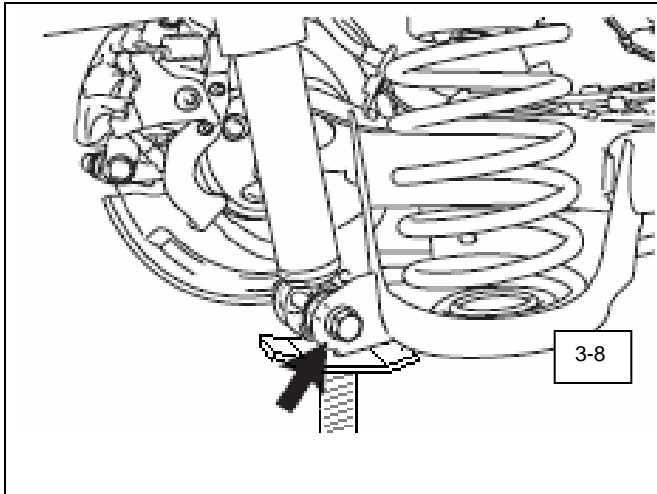

- (j) Now tighten the lower shock bolts.
 - (1) This bolt must be tightened with the load of the car on the tires.
 - (2) If using a post lift or jack first lower the vehicle and bounce it up and down several times to stabilize the rear suspension.

Torque: 90 N•m (918 kgf•cm, 67 ft•lbf)

NOTE: Because a locking nut is used, tighten the bolt head and not the nut. (Fig 3-8)

4. Clean Up

- (a) Ensure the RSB is clean and free of excess silicon grease.

STOP!



CONFIRM YOU HAVE TORQUED THE LOWER SHOCK BOLTS TO SPECIFICATION.



Checklist. These points MUST be checked to ensure a quality installation.

CHECK FOR:

Accessory Function Checks

Fastening Bolts Torque Specification

LOOK FOR:

Endlinks - Torque: 44 N•m (49 kgf•cm, 32 ft•lbf)

Bushing bracket bolts - Torque: 31 N•m (300 kgf•cm, 24 ft•lbf)

Vehicle Function Checks

There should be no noise from the rear suspension.

Confirm rear shock bolts are torqued properly.

Lower shock bolt - Torque: 90 N•m (918 kgf•cm, 67 ft•lbf)

NOTE: Because a locking nut is used, tighten the bolt head and not the nut.